

[CONTRIBUTION FROM THE CHEMICAL LABORATORY OF THE UNIVERSITY OF CALIFORNIA.]

## EQUILIBRIUM IN THE REACTION BETWEEN WATER AND SULFUR AT HIGH TEMPERATURES. THE DISSOCIATION OF HYDROGEN SULFIDE.

BY MERLE RANDALL AND F. RUSSELL V. BICHOWSKY.

Received October 16, 1917.

The equilibrium in the reaction of water vapor and liquid sulfur to form gaseous hydrogen sulfide and sulfur dioxide has been determined by Lewis and Randall<sup>1</sup> at the boiling point of sulfur. It was extremely desirable to study this technically as well as theoretically important reaction under different conditions, especially at higher temperatures, both in order to make sure of the exact nature of the reaction and for the purpose of obtaining the equilibrium constant at a different temperature. But the method of Lewis and Randall possessed such inherent difficulties, and was so peculiarly adapted to a temperature in the immediate neighborhood of that at which it was employed, that it seemed expedient to look for some entirely new method of attack.

In order to determine the equilibrium in this reaction we must know, besides the initial composition and the equilibrium pressure of the mixture, the partial pressure at equilibrium of at least one of the substances involved. In the experiments of Lewis and Randall this substance was the sulfur vapor, the partial pressure of which was fixed at one atmosphere by having the equilibrium mixture in contact with an excess of liquid sulfur at its boiling point. They have also shown that the rapidity of the reaction<sup>2</sup> precludes the use of the method of determining the equilibrium by quickly cooling the reacting substances and analyzing. An attempt to fix the partial pressure of the sulfur by replacing the liquid sulfur by a solid substance, which had a constant determinable vapor pressure of sulfur, proved unsatisfactory. Water vapor was passed over pure silver sulfide<sup>3</sup> at a red heat, but it was found that the quantity of hydrogen

<sup>1</sup> Lewis and Randall, *THIS JOURNAL*, **40**, 362 (1918).

<sup>2</sup> A mixture of moist SO<sub>2</sub> and H<sub>2</sub>S, when passed through a clean glass tube at 60°, deposited but little sulfur. However, when the tube was etched sulfur was deposited rapidly at the same temperature. At temperatures above 200° the reaction was rapid in any case.

<sup>3</sup> Silver sulfide was supposed, on the basis of preliminary experiments, to give off considerable sulfur when heated with water vapor at red heat. However the *c. p.* Ag<sub>2</sub>S which we used in these preliminary experiments was, apparently, a solid solution of Ag<sub>2</sub>S and S; at least Ag<sub>2</sub>S, which had been heated in a vacuum until partly decomposed, when treated with steam at 800° gave off very little S as H<sub>2</sub>S and SO<sub>2</sub>.

The apparatus which we used in the latter of these experiments is perhaps interesting. Since the yield is markedly dependent on the rate of flow, very slow and regular passage of the vapor is essential. This we secured by allowing the vapor to distil in vacuum through the furnace from one heated flask to another which was kept

sulfide and sulfur dioxide, measured by the amount of total sulfur carried over, was too small for accurate measurement.

If the system studied by Lewis and Randall is investigated at temperatures in the neighborhood of 1000°, with sulfur vapor in place of liquid sulfur, then in addition to the four substances involved in their reaction a fifth substance is present, namely, hydrogen. If then any mixture of gases containing only hydrogen, sulfur and oxygen (in not too large amount) is heated to a high temperature, an equilibrium is established between the five gases, water, sulfur dioxide, hydrogen sulfide, hydrogen and sulfur. But since the equilibrium between hydrogen, sulfur and hydrogen sulfide is already known at different temperatures it still suffices, in order to determine completely the composition of the gases in equilibrium, to know the original composition of the gaseous mixture, the total pressure, and the partial pressure of any one of the five gases.

The reaction between hydrogen and sulfur dioxide is apparently slower than that between hydrogen sulfide and sulfur dioxide, so that when the hot gaseous mixture is suddenly cooled small amounts of hydrogen remain uncombined with an excess of sulfur. It seemed unlikely however that this method would prove adequate for the determination of the partial pressure of hydrogen in the equilibrium mixture.<sup>1</sup>

A similar problem was met by Loewenstein,<sup>2</sup> in his investigation of the dissociation of water vapor, and by Preuner,<sup>3</sup> and by Preuner and Schupp,<sup>4</sup> in their study of the dissociation of hydrogen sulfide. They allowed the equilibrium gases to come in contact with an evacuated platinum or palladium bulb heated to the equilibrium temperature. At the temperature used the rate of diffusion of the hydrogen was rapid, that of the other gases not appreciable. The total pressure of hydrogen inside the platinum bulb was taken equal to the partial pressure of the hydrogen in the mixture of gases. This method we have adopted in the present investigation.

The gas mixture containing a constant known percentage of oxygen, hydrogen and sulfur dioxide was prepared in the apparatus shown in Fig. 1, which consisted essentially of two wide U tubes R and S in which a 10% solution of potassium hydroxide was electrolyzed between platinum electrodes. The U tubes were joined, as shown, so that the oxygen (or hydrogen) from either or both the generators could be sent through the at a slightly lower temperature. By regulating the temperature of the thermostats in which the two flasks were placed both the pressure and the rate of flow could be varied within wide limits.

<sup>1</sup> We were unable to use the excellent method of Langmuir (*THIS JOURNAL*, **28**, 1357 (1906)) as the mixed gases reacted rapidly with the platinum wire.

<sup>2</sup> Loewenstein, *Z. physik. Chem.*, **54**, 715 (1906).

<sup>3</sup> Preuner, *Z. anorg. allgem. Chem.*, **55**, 279 (1907).

<sup>4</sup> Preuner and Schupp, *Z. physik. Chem.*, **68**, 157 (1909).

sulfur burner EG, or directly into the furnace through Q, or to the atmosphere through N. A part of the oxygen was converted completely into sulfur dioxide by passing through the sulfur burner EG. This consisted of a large bulb filled with carbon-free sulfur which was kept boiling by allowing the tip of a quartz tube, F, heated to bright redness by passing a current through an enclosed coil of platinum wire, to dip under the surface

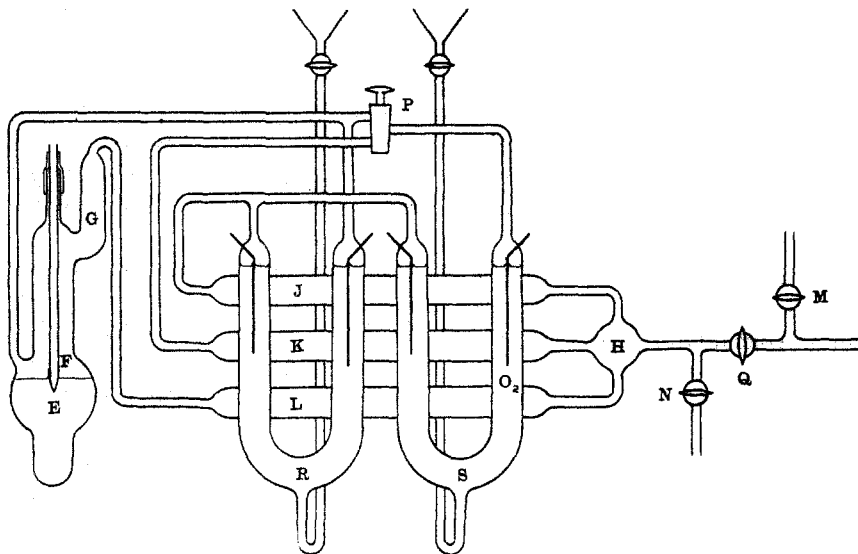

Fig. 1.—Apparatus for synthesizing a constant known mixture of  $O_2$ ,  $H_2O$  and  $SO_2$ .

of the sulfur. The sulfur vapor and oxygen were superheated by the upper part of the heated quartz tube, and the oxygen burned completely to sulfur dioxide.<sup>1</sup> The boiling of the sulfur was regulated by raising or lowering F, and the excess of sulfur vapor which was always present was condensed in the wide outlet tube G which had a plug of glass wool in the upper end. The gases from the sulfur burner and the U tubes were severally dried over phosphorus pentoxide in tubes J, K, L, and mixed in the bulb H which was filled with glass wool.

The two U tubes were connected, in parallel, in series with a lamp bank to the regular direct current mains. Variations in the voltage did not affect the ratio of the currents in the two tubes, which ratio was kept at any desired values by means of adjustable resistances, and checked by a modified Wheatstone bridge with an accuracy of 0.1%. The composition of the gas entering the furnace was determined by the position of the stopcock P and these bridge ratios.

The reaction furnace and manometer for determining the pressure of hydrogen in the platinum bulb are shown in Fig. 2. The furnace B was

<sup>1</sup> The absorption by KOH in two experiments was 99.85% and 99.98%.

simply a glazed porcelain tube (15 mm. inside diameter) wound with platinum wire and covered with an insulating cement. The plugs at the end were of the same cement. The gases were led into the reaction chamber through the quartz tube X, which was closely packed with platinum wire to prevent explosions, and the temperature was measured by the platinum platinum-rhodium thermocouple U connected to a sensitive potentiometer<sup>1</sup>

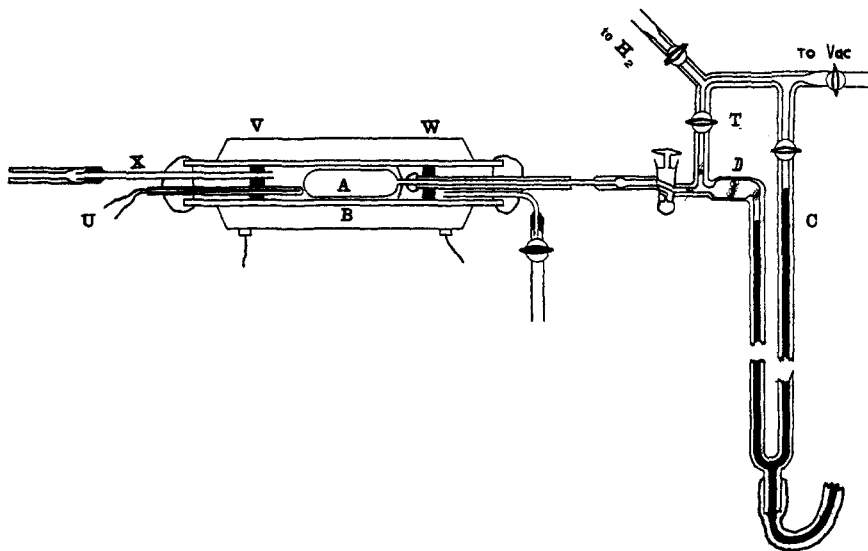

Fig. 2.—Reaction furnace and hydrogen manometer.

and carefully calibrated at  $100^{\circ}$ ,  $445^{\circ}$  and  $1062^{\circ}$ . The thermocouple was contained in a thin-walled quartz tube. The diffusion bulb A was made of platinum, for we found that although palladium has theoretical advantages, it was extremely fragile when heated. The bulb was filled closely with small quartz rods in order to decrease the gas space, which must be filled by diffusion, as much as possible, and to prevent the bulb from collapsing when evacuated. The furnace space was made as small as possible to ensure uniform heating. The insulating cement was a good thermal conductor and helped to maintain uniform temperature conditions inside the furnace. To prevent radiation from the bulb to the ends of the furnace a series of bright platinum and transite baffles V and W were introduced. The cooler portions of the furnace were packed with coarse alundum powder to prevent diffusion. A quartz tube exit for the reacting gases was provided. The stem of the bulb A was made of very heavy-walled platinum capillary tubing and was protected through the temperature gradient by a porcelain tube which was cemented over it. The platinum tube was fused into the manometer C (2 mm. inside diam-

<sup>1</sup> Randall, Bichowsky and Rodebush, *THIS JOURNAL*, **38**, 1266 (1916).

eter) which was compared with a standard barometer. Pure, dry hydrogen could be introduced from a side tube so that equilibrium could be approached from either direction. Vacuum stopcocks<sup>1</sup> were used throughout except in the generators (Fig. 1).

At the beginning of each experiment the tube F was brought to a bright red heat, the stopcock N opened, the stopcock Q closed, the bridge ratio adjusted, and the apparatus as far as Q swept out with a slow current of gas. The furnace was slowly heated to the required temperature and the tube A evacuated through T. Because of the somewhat rapid action of the sulfur gases on the platinum tube when heating or cooling, it was found advisable to heat and cool the tube in air and only expose it to the mixed gases from Q when heated. Under these conditions the tube was apparently unaffected.<sup>2</sup>

The evacuation of A was continued until no further residual gas was given off, as determined by cutting off the pump and noting the increase of pressure in C. The gas mixture was then introduced through X and the experiment allowed to proceed until the H<sub>2</sub> pressure in A was constant. The gas was then pumped out and pure, dry hydrogen introduced, from the reservoir not shown in the figure, until the pressure was slightly less than that of the original gas. When the pressure had again become constant the hydrogen was replaced by new hydrogen at a pressure slightly greater than equilibrium pressure. Thus the equilibrium was approached from both sides several times and the mean of the last two readings, which never differed by more than 1 to 2 mm. was taken.

In some earlier experiments there was a slight constant rate of diffusion or leak of other gases than hydrogen through the tube. In these cases the equilibrium pressure was estimated by plotting pressure against time and extrapolating back. Then the hydrogen pressure was made very slightly greater and less than this estimated value and the decrease or increase of pressure noted during the first minutes. The rate of leak was always very small and perfectly regular. The leak was eliminated in the last experiments by introducing a small drying tube (Fig. 2, D), filled with phosphorus pentoxide and potassium hydroxide, between the furnace and the manometer.

Our results are tabulated in Table I. The first column gives the absolute temperatures, Cols. 2 and 3 the ratios  $r$  and  $R$  defined by Equations 2 and 3, respectively (see below), Col. 4 the total pressure (barometric) in the furnace expressed in millimeters of mercury, Col. 5 the partial

<sup>1</sup> Randall and Bichowsky, *THIS JOURNAL*, 37, 137 (1915).

<sup>2</sup> At low temperatures platinum, when heated in gases containing S, takes on a beautiful crystalline structure (due to PtS<sub>2</sub>?) which, though destroyed at higher temperatures, apparently causes minute cracks, thus destroying the usefulness of the tube.

pressure of hydrogen at equilibrium expressed in millimeters of mercury, and Cols. 6 and 7 the quantities in the two preceding columns expressed in atmospheres.

TABLE I.

| T., abs. | r. | R.   | P. Mm. | [H <sub>2</sub> ]. Mm. | P. Atmos. | [H <sub>2</sub> ]. Atmos. |
|----------|----|------|--------|------------------------|-----------|---------------------------|
| 1160     | 2  | 0.50 | 756    | 7.7                    | 0.995     | 0.0101                    |
| 1362     | 2  | 0.50 | 756    | 24.3                   | 0.995     | 0.0319                    |
| 1473     | 2  | 0.50 | 753    | 39.7                   | 0.991     | 0.0521                    |
| 1473     | 2  | 0.25 | 753    | 43.2                   | 0.991     | 0.0566                    |
| 1645     | 2  | 0.25 | 754    | 74.0                   | 0.992     | 0.0972                    |

**Dissociation of Hydrogen Sulfide.**—The measurements of Preuner and of Preuner and Schupp<sup>1</sup> on the dissociation of hydrogen sulfide did not extend above 1405°A. We have extended their measurements over the range from 1362°A to 1667°A. The excellent agreement between the two independent investigations enables us to put reasonable reliance upon not only these results but also upon those for the equilibrium between water and sulfur since the method is so nearly identical. The experiments were made directly in the apparatus shown in Fig. 2 in an identical manner with the previous measurements, except that hydrogen sulfide was introduced through M instead of the sulfur-water mixture.

Pure, dry hydrogen sulfide was prepared by heating calcium sulfide with a saturated solution of magnesium chloride to about 60°, and drying the slow stream of gas, which was given off, over phosphorus pentoxide. This very excellent method, first suggested by Habermann,<sup>2</sup> for the preparation of pure hydrogen sulfide, gives a very regular and easily controlled stream of gas. The rate of reaction is regulated by raising or lowering the temperature of the reaction flask, and the gas is probably purer than that prepared by any other method known.

The results are given in Table II, in which Col. 1 gives the absolute temperature, Col. 2 the total pressure (atmospheric) of the equilibrium mixture, Col. 3 the observed hydrogen pressure at equilibrium, Col. 4 the equilibrium constant  $K_p = \frac{[H_2S]}{[H_2][S_2]^{1/2}}$  for the reaction  $H_2 + \frac{1}{2}S_2 = H_2S$ , and Col. 5  $\log K_p$ .

TABLE II.

| Temp., abs. | P. Mm. | [H <sub>2</sub> ]. Mm. | K <sub>p</sub> . Atmos. | Log K <sub>p</sub> . |
|-------------|--------|------------------------|-------------------------|----------------------|
| 1362        | 761    | 179                    | 7.98                    | 0.902                |
| 1473        | 761    | 235                    | 4.39                    | 0.643                |
| 1537        | 758    | 270                    | 3.08                    | 0.490                |
| 1667        | 758    | 325                    | 1.81                    | 0.257                |

The final values obtained by Preuner and Schupp<sup>3</sup> are given in Table III, in which the first row gives the absolute temperature and the second row the log of the equilibrium constant  $K_p$  calculated from their results.

<sup>1</sup> Preuner; Preuner and Schupp, *Loc. cit.*

<sup>2</sup> Habermann, *Chem. Zentr.*, [4] 2, 82 (1890).

<sup>3</sup> Preuner and Schupp, *Loc. cit.*

TABLE III

|                  |       |       |       |       |       |
|------------------|-------|-------|-------|-------|-------|
| Temp., abs. .... | 1023  | 1103  | 1218  | 1338  | 1405  |
| Log $K_p$ .....  | 2.025 | 1.710 | 1.305 | 0.964 | 0.793 |

These results will be discussed further in a later paper.

**Calculation of the Partial Pressures in the Equilibrium between Water and Sulfur.**—Five gases were present at equilibrium and the following five condition equations, solved simultaneously, enable us to calculate the partial pressures of each of the gases:

$$[\text{H}_2] + [\text{S}_2] + [\text{H}_2\text{S}] + [\text{H}_2\text{O}] + [\text{SO}_2] = P \quad (1)$$

$$\frac{2[\text{H}_2] + 2[\text{H}_2\text{O}] + 2[\text{H}_2\text{S}]}{[\text{H}_2\text{O}] + 2[\text{SO}_2]} = r \quad (2)$$

$$\frac{2[\text{S}_2] + [\text{H}_2\text{S}] + [\text{SO}_2]}{[\text{H}_2\text{O}] + 2[\text{SO}_2]} = R \quad (3)$$

$$\frac{[\text{H}_2\text{S}]}{[\text{H}_2][\text{S}_2]^{1/2}} = K_{\text{H}_2\text{S}} \quad (4)$$

$$[\text{H}_2] = x \quad (5)$$

In the above equations the symbols in brackets represent the partial pressures of the several gases,  $P$  the total pressure (atmospheric) at equilibrium,  $r$  the ratio of total hydrogen to total oxygen determined from the composition of the initial gases,  $R$  the ratio of total sulfur to total oxygen,  $K_{\text{H}_2\text{S}}$  the equilibrium constant for the dissociation of hydrogen sulfide, and  $x$  the measured partial pressure of hydrogen.

Equations 1, 4 and 5 are obvious and require no comment. Equation 2 was arrived at in the following manner: All the hydrogen and oxygen generated in the apparatus (Fig. 1) was present in the equilibrium mixture. If these gases existed in the equilibrium mixture as hydrogen and oxygen, the ratio  $[\text{H}_2]/[\text{O}_2] = r = 2$ . Some of the hydrogen, however, changed to water and hydrogen sulfide and some of the oxygen to water and sulfur dioxide. For each mol of hydrogen at constant volume changed to water and hydrogen sulfide, and each mol of oxygen changed to sulfur dioxide there will be no change of pressure. For each mol of oxygen changed to water, however, the pressure will be doubled. If we take half the partial pressure of the water in the equilibrium mixture and clear the equation of fractions we may write  $[\text{H}_2]/[\text{O}_2] = r$  in the form given in Equation 2.

In the first three experiments all and in the last two only one-half of the oxygen generated was passed through the sulfur burner EFG (Fig. 1). For each mol of sulfur gas burned to sulfur dioxide two mols of oxygen were used. Therefore  $[\text{S}_2]/[\text{O}_2] = R = 0.50$  in the first three and 0.25 in the last two experiments. Proceeding as above we obtain the equation in the form given in Equation 3.

With the aid of the values of  $K_p$ , interpolated from Tables II and III

and given in the second column of Table IV, and the data given in Table I, we may solve Equations 1-5 simultaneously and obtain the partial pressures of the five gases present at equilibrium. Col. 1 gives the absolute temperature, Cols. 3-7 inclusive the partial pressures in atmospheres of the hydrogen, hydrogen sulfide, sulfur dioxide, sulfur and steam, respectively.

TABLE IV.

| Temp., abs. | $K_{H_2S}$ | $[H_2]$ | $[H_2S]$ | $[SO_2]$ | $[S_2]$ | $[H_2O]$ | Log K. |
|-------------|------------|---------|----------|----------|---------|----------|--------|
| 1160        | 32.8       | 0.0101  | 0.111    | 0.0615   | 0.117   | 0.694    | 5.93   |
| 1362        | 7.98       | 0.0319  | 0.090    | 0.061    | 0.126   | 0.685    | 4.32   |
| 1473        | 4.39       | 0.0521  | 0.081    | 0.067    | 0.126   | 0.665    | 3.59   |
| 1473        | 4.39       | 0.0566  | 0.057    | 0.057    | 0.053   | 0.767    | 3.50   |
| 1645        | 3.20       | 0.0972  | 0.044    | 0.0715   | 0.051   | 0.725    | 2.56   |

It will be shown in a later paper how these results may be used in the calculation of the free energy of sulfur dioxide. We have given in Col. 8 the log of the equilibrium constant  $K_p = [H_2O]^2[H_2S]/[H_2]^3[SO_2]$  for the important reaction  $3H_2 + SO_2 = 2H_2O + H_2S$ . It is of course possible to calculate from the partial pressures given in Table IV the equilibrium constant for a number of different reactions. These equilibria may best be studied, however, by summing the free energies of the various substances used up and produced in the reactions.

In conclusion the authors wish to thank G. N. Lewis for his kindly interest and many suggestions during the progress of this research.

BERKELEY, CAL.

[CONTRIBUTION FROM THE PHYSICAL LABORATORY, UNIVERSITY OF MICHIGAN.]

## THE SCATTERING OF ALPHA RAYS AS EVIDENCE ON THE PARSON MAGNETON HYPOTHESIS.

By DAVID L. WEBSTER.

Received October 20, 1917.

The essential feature of Parson's theory of atomic structure<sup>1</sup> is the hypothesis that the electron is not a sphere, but a very thin ring, perhaps as much as  $1.5 \times 10^{-9}$  cm. in radius, carrying a charge of negative electricity that circulates around the ring at a very high velocity. This gives it in addition to its electrostatic properties the magnetic properties of a coil of wire carrying a current. This hypothesis was used very successfully by Parson in explaining an extraordinary variety of chemical phenomena, and I have also found it useful as the basis of a theory of heat radiation that is consistent with Planck's law and at the same time with the classical electro-dynamical system and the numerous phenomena explained only by that system.<sup>2</sup> The magneton hypothesis, however,

<sup>1</sup> A. L. Parson, "A Magneton Theory of the Structure of the Atom," Smithsonian Miscellaneous Collections, 65, No. 11 (1915).

<sup>2</sup> D. L. Webster, *Proc. Amer. Acad.*, 50, 131-145 (1915).